

F820 – Service and Parts Manual

Ver. FC031504



TABLE OF CONTENTS

I. SPECIFICATIONS / MAINTENANCE

A. General Specifications & Measurements	3	B. Safety	3
C. Transport Considerations	3	D. General Cleaning Considerations	3
E. Freezer Maintenance	3	F. Removing The Control Console	4
G. Troubleshooting Tips	5	H. Transformer Reset Checks	5

II. SETUP INSTRUCTIONS

A. Money Systems	6		
1. MDB Coin Mechanism & Bill Acceptor Installation			
B. Initial Power Up (Homing Sequence)	6		
C. Bin Setup/ Product Loading	6		
D. Preprogramming Configuration (DIP Switches)	8		
1. Clearing the Memory	8		
E. Programming (Overview of Menu Structure)			
1. Getting started / Creating Selections	9	12. Set Service Phone #	13
2. Programming & editing after machine has been operating	10	13. Sales PIN Code	14
3. Change Price	10	14. Vend Block	14
4. Sales Meters Total	10	15. VB PIN Code	14
5. Sales Meters Resetable	10	16. Health Timer	15
6. Edit Selection	11	17. Program Version	15
7. Create Selection	12	18. Display Language	15
8. Delete Selection	13	19. Line Mode	15
9. Selection #s	13	20. Machine Serial Number	15
10. Set Date	13	21. Group Sales Option	15
11. Set Time	13	22. Tokens & Coupons	16
F. Free Vend / Test Vend	17	23. Field Test	16

III. Troubleshooting

A. Glossary Of Useful Terms	17		
B. Error Reporting Features			
1. Non-Fatal	17		
2. Fatal	18		
C. Order Of Operation			
1. Initiating The Vend Cycle	19	6. Picker Head Moves Up	20
2. Robot Carriage Moves Back	19	7. Robot Moves Left/Right	20
3. Robot Moves Right	19	8. Robot Carriage Moves Forward	21
4. Picker Head Moves Down	19	9. Vend Cycle Complete	21
5. Vacuum turns on	20		
D. Troubleshooting Logic / Charts	22		
1. L/R Stuck Motor	22	8. U/D Encoder Error	31
2. F/B Stuck Motor	23	9. Out Of Product	31
3. U/D Stuck Motor	25	10. Vacuum Out Of Order	31
4. Freezer Stuck Closed	26	11. Bin Errors	33
5. Freezer Stuck Open	28	12. False Vend	33
6. L/R Encoder Error	30	13. Product Sensor Error	34
7. F/B Encoder Error	30	14. Health Sensor Active	35
E. Parts Replacement Instructions			
1. Console	36	6. Freezer Door Motor	41
2. Computer Board	37	7. Picker Head Assembly	42
3. Front / Back Motor	39	8. Health Sensor Assembly	42
4. Left / Right Motor	40	9. Bubble Front Display	44
5. Up / Down Motor	40		

SPECIFICATIONS / MAINTENANCE

GENERAL SPECIFICATIONS, ELECTRICAL

HEIGHT:	72.0 in./182.9 cm.	VOLTAGE:	110-115 A/C
WIDTH:	39.0 in./90.20 cm.	FREQUENCY:	60 Hz *
DEPTH:	34.5 in./87.70 cm.	AMPERAGE:	9Amps.
WEIGHT:	635-lbs./288 kg.	AMP DRAW:	2.5Amps resting /9Amps operating

* This machine requires a 115V, 15 Amp dedicated circuit. Lower voltage may result in vacuum related problems and/or improper coin acceptance.

SAFETY CONSIDERATIONS

- Only use a 115V 15 Amp electrical power supply with ground to power the machine
- Keep clear of robot path during vend cycles (inside cabinet or near robot carriage assembly). When vending product, the robot accelerates towards the front center section of the cabinet known as the "Drop Point". Standing or looking inside the cabinet while the robot attempts to dispense product may result injury.

TRANSPORT CONSIDERATIONS

- Laying the F820 on its side will create issues in the freezer compressor. If the machine must be laid down for delivery purposes, be sure to stand the machine up for at least 24 hours before plugging and powering.
- Whenever the F820 is moved or transported, always use the shipping brackets provided when the machine was first delivered and new tie wraps. Refer to the uncrating instructions for tie wrap and shipping bracket installation.

LUBRICATION

- Do not use oil or other lubricants on any moving parts

GENERAL CLEANING CONSIDERATIONS

- **Note:** Do not use water, soap or any other liquid to clean inside the machine.
- The outside of the machine can be cleaned with a mild detergent.

FREEZER MAINTENANCE

Two or three hours after powering the machine, the freezer temperature should drop to -15°F/-26°C. Any temperature adjustment can be made using the thermostat, located in the back right side of the freezer. The freezer is set for -15°F/-26°C and may be adjusted using a standard screwdriver. Turn the screwdriver clockwise for colder and counter-clockwise for warmer. The range of operation temperature is -25°F/-31°C to 15°F/9°C (at 70°F/21°C ambient).

The standard chest freezer inside the F820 does not self-defrost automatically. The freezer chest requires maintenance when ice begins to affect the vend cycle, product loading, or the closing of the freezer door. The refrigeration system does not require any maintenance. Depending on the location's moisture level (relative humidity) and frequency of operation, ice deposits will occur primarily around the top three to four inches of the freezer. It is not necessary to defrost the freezer every time there is ice build up.

Ice can be chipped away as long as it does not make its way down along the walls or underneath the bins. Excessive ice build-up may require bin removal. The freezer does not have to be unplugged to perform this process.

FASTCORP recommends keeping a plastic ice scraper (provided with the machine), and a 9" by 11" piece of cardboard or plastic inside the machine. Place the plastic under the area to be scraped to catch the ice from falling in the bins. This entire process should only take only a few minutes.

Depending on usage, temperature and humidity, a full cleaning may be necessary. First, press the load button and remove all the bins and the bin matrix. Next, place the ice cream in a holding container. Scrape the ice and remove it from the basin.

To rinse out the freezer chest, place a drain pan under the drain and remove the drain plugs. One is located on the inside left of the freezer and the other on the outside lower left (a standard screwdriver might be necessary). Finally, reload the old bins or replace with new ones. Run each selection to make sure the bins did not shift or were put in the wrong location. The freezer will take about 2-3 hours to get down to temperature.

Under normal conditions, the F820 can be unplugged with the door closed for up to 12 hours without harming the product. If freezer temperatures reach unsafe levels, the health switch (located on the step in the rear right corner of the freezer) will activate and the machine will be placed out of order. Your product

must be discarded and proper cleaning procedures must be taken.

The screen will read "**Health Sensor Active**". It will not operate until both the RESET button is pressed and the freezer temperature has returned to safe levels. The machine is set not to accept money if the freezer has not reached proper operating temperatures. If the machine must be operated, even though the freezer is not at an acceptable temperature, you can bypass the health sensor.

REMOVING THE CONTROL CONSOLE

During initial placement or transporting, it may be necessary to remove the control console in order to fit the machine through narrow doorways.

1. The cover from the computer board can be removed one of two ways:

2. Loosen three (3) ¼" head screws. Lift the cover up and off. Remove one (1) of the two (2) 3/8" head bolts holding the top of the console onto the cabinet

3. Remove the top two (2) 3/8" head bolts and loosen the bottom 1/4" head bolt. Lift the cover up and off. Reinstall one (1) of the 3/8" head bolts. Leave one (1) of the bolts in place to prevent the console from accidentally falling.

4. With a permanent marker, number each of the FFC cables with the corresponding connector number printed on the intermediate board (J-24, J-25....). Mark the 2-pin connector, which plugs into J-28 (VAC sensor, below the ground wire). Remove the 2-pin connector and all cables from the board.

5. Label and remove the following connectors from the computer board:

6. *J-15 Door (2 pin, top left, twisted wires)*

7. *J-4 Triac (left side lower, 12 pin w/wires at location 1 and 12 only)*

8. *J-1 Power (4 pin, bottom left)*

9. *J-11MDB (J11, 6 pin, right side, middle, white connector/white wires)*

10. Remove the coin box and remove the bottom two (2) 3/8" heads bolts with 7/16" nuts that hold the console to the cabinet.

11. Pull the cables and wires through the holes, out the back of the console. Remove the wiring harness from the retainers on the back of the console. Cut tie wraps as needed making note of their location so that they can be accurately replaced during reassembly.

12. Loosen the three (3) bolts that hold the back of the console to the side of the cabinet. The holes are slotted and do not require complete removal.

13. While supporting the console, remove the top bolt (originally left in to prevent the console from accidentally falling). Remove console.

14. To reinstall console, reverse steps. Make sure that wires, cables and harnesses are properly connected. Replace original wire ties.

Troubleshooting Tips

- When checking continuity both ends of the harness to be tested should be unplugged (unless otherwise noted). If either end is connected, the results may be inaccurate.
- The freezer's temperature control can be found on a small rectangular box that is mounted behind the right, rear corner of the freezer. Turn the screw clockwise to make it colder, and counter-clockwise to make it warmer.
- The F820 uses several parts in multiple locations. These parts may be swapped during troubleshooting to determine if the suspected part is faulty. These parts include the 24VDC motors (4 locations) and the limit switches (5 locations).
- Always keep a small jumper wire or small paperclip in your toolbox for troubleshooting.
- Unless otherwise noted, *ALWAYS* remove power from the machine before testing any wires to avoid electrical shock.
- *ALWAYS* remove power from the machine before removing or installing any money systems (coin mech, bill acceptors, etc.) to avoid damaging the units.
- Anytime the display reads "Out of Order", press the "#" key to view the error message.
- If you require assistance in troubleshooting, please have the serial number, error code and a description of the problem available before calling. The toll free number to call is 1-888-441-3278 and press 2 for the service department.
- If your meter does not have a continuity setting, set it to read OHMS (Ω). Hold the leads apart, the meter should read 1 or OL. This means the circuit is open (no continuity). Touch the two leads together, the display should show 0 (or something close to 0 like .0001). This means the circuit is closed (has continuity). If you touch each lead to an end of a wire, you can determine if the wire is whole or broken.

Transformer Reset Troubleshooting

Turn power off. Unplug connector J18 from the main computer board. Reset the breaker and turn the power on. Does the breaker trip?

NO – Unplug 1 motor at a time, resetting the breaker in between until the reset does not trip. This is the faulty motor.

YES – Reconnect J18 and unplug J1 from the computer board. Reset the breaker and turn the power on. Does the breaker trip?

NO – There is a short in the computer board. Replace the computer board.

YES – Reconnect the J1 connector. Behind the transformer is a square, black rectifier. Unplug the two wires from the right side of the rectifier that go to the 24v fan. Does the breaker trip?

NO – There is a short in the rectifier or fan.

YES – Call Fastcorp Service for further assistance.

SETUP INSTRUCTIONS - MONEY SYSTEMS

1. The F820 machine supports **ONLY** MDB (Multi-drop Bus) 24V Money systems.
2. The F820 machine is compatible with any MDB compliant coin mechanism and bill acceptor.
3. **A dollar coin block plate is provided to prevent dollar coins from being inserted. The plate can be removed to accept dollar coins.**
4. The F820 comes pre-wired for a DEX port located on the inside of the control panel. To collect DEX data, insert the DEX plug into the phono jack and pull out the vend / service interlock switch located at the bottom right of the cabinet.

MONEY SYSTEM INSTALLATION Multi-Drop Bus (MDB) Interface

1. With machine powered OFF.
2. Open the control panel-cover using the release button located on the right side of the control panel.
3. Mount the coin mechanism using the three coin mech. mounting screws.
4. Mount the bill acceptor using the four mounting screws located on the control panel cover (top or bottom slot depending on type of acceptor used; for card readers, use top slot- MDB only)
5. Make all the connections.
6. Power up machine, following **INITIAL POWER UP** procedure below!

INITIAL POWER UP

Plug the machine into the power source. To avoid the risk of injury, making sure that all body parts are clear of the cabinet before turning on the main power.

The robot should follow the initial power-up sequence:

1. Robot picker head moves UP.
2. Robot carriage moves towards the LEFT of the cabinet.
3. Robot carriage moves towards the FRONT of the cabinet (considered the HOME position).

If the robot does not move or follow the “Homing Sequence”:

1. There may be setup errors or shipping damage. Review all the previous sections and check for errors on the display. If the machine is out of order press the # key for diagnosis.
2. Check the transformer reset breaker and make sure the power switch is on (refer to control panel diagram for location).
3. Perform a quick check to see if there are obstructions preventing the robot from moving freely on all axes.
 - a. Power the machine off to disable “dynamic breaking” features that make it hard to move the robot manually.
 - b. Manually move the robot to the left, right, front and back. Check for smooth travel. Note any obstruction or gear binding.
4. Refer to the Troubleshooting Guide section.

BIN SETUP / PRODUCT LOADING

The F820 utilizes a bin system to hold product. The bin system is made up of a number of bins (various shapes and sizes), held together by a plastic bin matrix. The type and size of bin used depends on the size and shape of the product being vended. Every machine comes pre-configured with a specific bin layout or “Bin Plan-o-gram”.

GENERAL CONSIDERATIONS

1. To keep track of products in a bin configuration, we recommend that the plan-o-gram form be filled out and attached to the inside of the machine. The product name, price and bin number can also be written directly on each bin. In addition, the computer is programmed to leave one product at the bottom of each bin allowing products to be matched by the service person for refilling.

2. Always keep a copy of each machine's specific bin plan-o-gram at a remote location (office) as a reference and backup copy.
3. Each bin size comes in two different bin heights: tall and short. Short bins are approximately $\frac{1}{2}$ the size of the long bins and are located on the right side of the chest freezer above the compressor. In a typical configuration, there are a total of four short bins. Short bins do not have to be programmed and can be used for product overflow or storage.
4. Always load product from the bottom-up (so that product will be vended FIFO: First In, First Out).
5. The standard bin configuration holds a majority of all ice cream novelties. Spacers and inserts are provided for products such as ice cream cones, sandwiches and Snickers. However, if there are products that require special bins, contact the *FASTCORP* service dept. for alternative bin shapes and spacers. When reordering bins, refer to the bin part numbers detailed in the machine's bin plan-o-gram.
6. Always keep an extra set of bins and a plastic bin matrix on hand in the event of a meltdown. Bins can be removed quickly and new bins can easily be installed.
7. There should not be more than a $\frac{1}{2}$ inch gap between the product and bin in any direction. Use smaller bins or the proper spacers to ensure product retrieval.
8. *FASTCORP* recommends placing the best selling items on the left side of the freezer. This shortens the distance the robot must travel, reducing cycle time.

PREPROGRAMMING CONFIGURATION

CONTROLLER BOARD DIPSWITCH OPTIONS

Switch #	Description	Operation
1	ESCROW	ON to enable bill acceptor escrow which prevents more than one bill to be inserted per vend
		OFF to disabled escrow
2	SELECTION DIGITS	ON to make selection 2 characters
		OFF one character
3	FORCE VEND	ON to enable force vend (customer must attempt to make a vend); prevents the unit from being used as a change machine. The machine will not advance further into the vend cycle until the customer makes a selection.
		OFF allows change to be dispensed using the coin return.
4	NOT USED	No function
5	AUTO-TEST	Used only for factory testing
6	NOT USED	No function

Clearing the Memory - Even after computer boards or chips have been changed, legacy selection numbers and bin locations may still exist in memory. To completely clear the machine's memory:

1. Power down the machine.
2. Turn all dipswitches to "on" on the computer board.
3. Power up the machine.
4. The screen will display "Factory Test Press Any Key". Press a key and the screen will change to "Testing External RAM" for about one second.
5. The screen will display "Checking Real Time Clock". Disconnect the power and return the dipswitch settings to normal.

PROGRAMMING

INTRODUCTION

The machine comes from the factory without any preset selection numbers or bin locations in memory. All information is entered during initial setup and programming. Programming is completely menu driven. Simply scroll through the menus until the desired function is reached. Once inside a menu function, the computer will prompt the user to enter the required information. Programming Menus can be accessed in Service Mode. The machine enters Service Mode every time the cabinet door is opened. A list of menu items can then be viewed on the digital display by pressing the "*Next" key on the customer keypad. In the event that there are bin and sold out errors in memory, the errors are displayed before the programming menus.

Note: if the machine is programmed in one location and transported to another, (for example in your warehouse) it is important to re-level the machine at the new location and perform test vends on each selection. Reprogram/edit bins where required.

Programming Menus

1	CHANGE PRICE:	Allows the price to be changed.
2	SALES METERS:	Allows sales data to be viewed. The total sales meter is non-resettable, and offers a total sales and unit counter.
3	EDIT SELECTION:	Allows existing selections to be edited: Price, Product Height (1-4 in.) and Bin (adjust bin location, add bins to the selection number or change bin height).
4	CREATE SELECTION:	Allows a selection to be created.
5	DELETE SELECTION:	Allows a selection to be deleted.
6	SELECTION NUMBERS:	Allows programmed selection numbers to be viewed
7	SET DATE:	Allows date to be set or viewed.
8	SET TIME:	Allows time to be set or viewed. Military / 24 hr time.
9	SERVICE PHONE #:	Allows service phone number to be set. The number is displayed when the machine is out-of-order.
10	SALES PIN CODE:	Allows pin code to be set and viewed for machine auditing. Sales meters can be viewed without opening the door. DEFAULT: #, *, 1, 2, 3, 4
11	VEND BLOCK:	Allows machine to be disabled for predetermined periods of time.
12	VEND BLOCK PIN CODE:	Allows pin code to be set and viewed and allows access to vend block times from outside the machine.
13	HEALTH TIMER:	Allows the health sensor to be bypassed for up to 4 hours.
14	PROGRAM VERSION:	Displays current version of operational software (e-prom).
15	DISPLAY LANGUAGE:	Allows programmer to choose language displayed on screen.
16	LINE MODE:	Allows machine to detect a customer line and shorten vend time.
17	MACHINE SERIAL NUMBER:	Allows programmer to program serial number of the vendor for machine identification during DEXing.
18	GROUP SALES OPTION:	Allows programmer ability to have up to four metered accounts.
19	TOKENS & COUPONS:	Allows for the use for tokens and coupons.
20	FIELD TEST:	Allows all functions of the machine to be tested.

GETTING STARTED; CREATING SELECTIONS

- 1) Before creating a selection, the front product display must be setup. Product and bins must be preloaded in the machine.
- 2) In Service Mode, press the “*Next” key and scroll to “4 CREATE SELECTION”. “4 CREATE SELECTION” allows new selections to be created (Note: do not start programming yet).
- 3) Menu item “4 CREATE SELECTION” will require the following information to be entered:

1	Enter a selection number:	A1 to D1
2	Enter the price:	\$.05-\$9.95
3	Enter the height of the product:	1-4 inches
4	Move the robot over center of the product:	Controls on service keypad: front/back, left/right, down/up
5	Enter the length of the bin:	Short/tall
6	Add more than one bin for the selection:	Yes/No

- 4) In the Programming Menus section, locate the flow chart for the menu item “4 CREATE SELECTION” and follow the step-by-step instructions for programming new selections.
- 5) Once selections have been programmed, use the other available menu items to edit and select operating preferences. Refer to Menu Item Description for an overview of each menu item and its features.
- 6) Once programming is complete, it is important to perform a test to make sure that the machine was programmed correctly. By pressing “Free Vend” on the Service keypad, the machine will

allow menu selections to be vended without money and without affecting sales meters. Test each bin selection. Press “Free Vend” again to deactivate this feature. “Test Vend” on the service keypad allows money to be inserted in order to test menu selections without affecting sales meters. Money deposited will be returned after each test vend. Press “Test Vend” again to deactivate this option.

PROGRAMMING/EDITING AFTER THE MACHINE HAS BEEN OPERATING

- 1) After the machine has been programmed and operating in the field, any sold out or bin errors that have occurred will be displayed once the door is opened (Service Mode). A bin error occurs if the robot has made three unsuccessful attempts to retrieve a product from a single bin. An “Out Of Product” is displayed when a bin is determined empty.
- 2) Do not press “* Exit” before viewing all bin errors. To scroll through the list of all bin errors including selection and bin number, use the “#Next” key on the customer keypad. **NOTE: it is important to view all before loading or editing of bin selections**
- 3) Perform a “Free Vend” on these bins to verify that the robot was programmed over the center of the product and that product was loaded properly.
- 4) To clear all bin errors and “Out Of Product” bins, press “Load” and then “Close” on the service keypad. The display must be in the main menu for this to work (ie. 1) CHANGE PRICE).
- 5) The machine is ready to be edited and/or loaded with product.

MENU ITEM PROGRAMMING SEQUENCE

1) CHANGE PRICE - Changing the price of programmed selections.

Display	Programming Instructions
1) CHANGE PRICE * = Next Menu # = Yes	a) Press the #=Yes key.
Edit Selection #: _ _ * = Exit	b) Enter the selection number.
A1 Price: \$1.00 *=Abort #=Yes	c) Type over the price.
A1 Price: \$1.50 Accept? *=No #=Yes	d) Press the #=Yes key to enter the price change.

2A) SALES METERS - Choose from two types of sales meters: (a) Non-Resetable (total cash and unit meter that cannot be reset) and (b) Resetable (offers individual and total sales by product which can be cleared/reset).

Display	Programming Instructions
2) SALES METERS * = Next Menu # = Yes	a) Press the #=Yes key.
Choose Meter Type * = Total # = Resetable	b) The Total Meter is a non-resetable sales and unit counter.
Total = \$1575.30 Units = 975 #=Exit	c) Press the #=Exit key to exit and return to SALES METERS.

2B) RESETABLE SALES METERS

Display	Programming Instructions
2) SALES METERS * = Next Menu # = Yes	a) Press the #=Yes key.
Choose Meter Type * = Total # = Resetable	b) The # key to enter resetable meter
A1: \$50.00 25 *Scroll #Next	c) Press * Scroll key to view each selection’s sales or # Next key to view total sales.
\$ 10,250 5,000	d) Press the *= Clr key to clear the meter or

Display	Programming Instructions
*=Clr 1/01/95 #=EXIT	#=Exit key to save information.
Are You Sure? *=Yes #=Exit	e) Press the *=Yes key to erase the meter.

3) EDIT SELECTION - Choose from three sub-menus: (a) Change Price, (b) Product Height, (c) Edit Bins- adjust bin location and add bins to a selection number.

Display	Programming Instructions
3) EDIT SELECTION * = Next Menu # = Yes	a) Press the #=Yes key.
EDIT SELECTION #_ _ * = Exit	b) Enter selection number to be edited. Choose from three sub-menus.
Change Price (Sub-Menu)	Edit selection prices.
Change Price * = Next # = Yes	c) Press the #=Yes key or move to the next sub menu.
A1 Price: \$1.00 *=Abort #=Yes	d) Type over the price and press the #=Yes key.
A1 Price: \$1.50 Accept? *No #=Yes	e) Press the #=Yes key to enter the price. Next change product height.
Product Height (Sub-Menu)	Enter the height of the product (1-4 inches). Robot leaves one product at the bottom of bin so the service person can match the products.
Product Height *=Next #=Yes	a) Press the #=Yes key to alter Product Height.
A1 Height: 1inch (1-4) *=Next #=Yes	b) Press the *=Next key for heights 1-4 inches. Press #=Yes key to enter new product height.
A1 Height: 3inches Accept? *No #=Yes	c) Press the #=Yes key to enter the product's height.
Edit Bins	Adjust bin location, add bins to a selection.
Edit bins (Sub-menu) *=Next #=Yes	a) Press the #=Yes key to enter.
A1 Program bin #1? *=Abort #=Yes	b) Robot moves to location of A1, bin one. Press #=Enter key to verify location of bin 1, the robot will move to programmed location. You may accept current location or make adjustments using service keypad.
A1 Move the Robot *=Cancel #=Accept	c) Press #=Accept key to store location of the robot.
A1 Bin Height: Short? (Tall) *=Next #=Accept	d) Press *=Next key to select tall or short bin, then press #Accept key to store bin height. Note: short bins are located on top of the freezer compressor, usually the three rear/right bins and the front right bin.
A1 Bin Height: Short Accept? *No #=Yes	e) Press the #=Yes key.
More Bins? *=No #=Yes	f) Press #=Yes key to program / edit additional bins #2, 3, or 4 for selection A1 or press *=No key to store just one bin. (Program is stored).

5) DELETE SELECTION - Delete the selection.

Display	Programming Instructions
5) DELETE SELECTION* *=Next Menu #=Yes	a) Press the #=Yes key to enter menu item.
Delete Selection #: A1 (All selections) D=Delete *=Exit #=Next	b) Press the #=Next key to list selection numbers. Press the D=Delete key to delete the selection.
Delete Selection # A5 OK? *=No #=Yes	c) Press the #=Yes key to delete selection

6) SELECTION #S - View the current programmed selection numbers.

Display	Programming Instructions
*=Next Menu #=Yes	a) Press the #=Yes key to view selection numbers.
Programmed: A1 *=Exit #=Next	b) Press the #=Next key to list selection numbers.

7) SET DATE - Set or view the current date.

Display	Programming Instructions
*=Next Menu #=Yes	a) Press the #=Yes key to enter set date menu.
Enter Date: 01/01/03 *=Abort #=Enter	b) Type new date, press the #=Enter key to store. Date format: MM/DD/YY
Enter Date: 01/05/03 Accept? *=No #=Yes	c) Press the #=Yes key to store new date.

8) SET TIME - Set or view the current time.

Display	Programming Instructions
*=Next Menu #=Yes	a) Press the #=Yes key to view menu selection.
Enter Time: 15:30:00 (<i>military time</i>) *=Abort #=Enter	b) Type current time and press the #=Enter key. Use military time when setting.
Enter Time: 15:45:00 Accept? *=No #=Yes	c) Press the #=Yes key to store the current time.

9) SET SERVICE PHONE # - Enter, update, or view the service phone number. The programmed number will appear on the display screen in the event that the machine goes out-of-order.

Display	Programming Instructions
*=Next Menu #=Yes	a) Press the #=Yes key to enter menu selection.
Phone (###) ### - ##### *Abort	b) Type in service phone number.
Phone (###) ### - ##### Accept? *No #Yes	c) Press the #=Yes key to store.

10) SALES PIN CODE - View or change the PIN code that can access sales information without opening the door; while in "Please Insert Money" mode, Press # * and the four numbers you selected.

Display	Programming Instructions
10) SALES PIN CODE *Next Menu #Yes	a) Press the #=Yes key to view or change sales pin code.
Enter Pin: #*1234 *=Abort	b) Type in new four-digit number.
Enter Pin: #*1996 Accept? *No #Yes	c) Press the #=Yes key to store pin number.

11) VEND BLOCK - Block out vending up to four times per day, seven days per week. Time and date must be entered correctly in SET TIME and SET DATE programming.

Display	Programming Instructions
11) VEND BLOCK *Next Menu #Yes	a) Press the #=Yes key to enter menu selection.
Vend Block: Off (On) *=Scroll A=Abort #Enter	b) Press the *=Scroll to turn vend block on and press the #=Enter key.
Day: Sun A=Abort C=Copy D=Delete *=Scroll #Enter	c) Press *Scroll to the day you wish to begin and press the #=Enter key.
Mon Blk 1 on _ _ : _ _ *=Abort #Enter	d) Type in the first time you would like vending to be off and press the #=Enter key.
Mon Blk 1 On 09:00 (military time) Accept? *No #Yes	e) Press the #=Yes key to store the time.
Mon Blk off _ _ : _ _ *=Abort #Enter	f) Type the time you want vending to resume and press the #=Enter key
Mon Blk 1 off 11:00 Accept? *No #Yes	g) Press the #=Yes key to store the time; repeat up to four blocks per day.
Mon Blk 2on _ _ : _ _ *=Abort #Enter	h) Press the *=Abort key at end of the needed blocks, or press enter to continue more blocks.
Day: Mon A=Abort C=Copy (Copies information from day to day) D= Delete *=Scroll #Enter	i) (C=Copy: copies information from day to day) To copy one day to another, press *=Scroll key to the day you want to copy, then press the #=Enter key.
Copy Mon to Tues Accept? *No #Yes	j) Press the #=Yes key to copy.

12) VB PIN CODE - Set or alter the VEND BLOCK option from the outside of the machine without opening the door.

Display	Programming Instructions
12) VB PIN CODE *Next Menu #Yes	a) Press the #=Yes key to enter VB Pin code menu.
VB PIN CODE: #*5678 *=Abort #Yes	b) Vend block pin code is factory set at #*5678. Use factory setting or type over four new digits and press the #=Yes key. Type this code when you are in "Please Insert Money" mode to gain direct access to VEND BLOCK menu item.

13) HEALTH TIMER - Allows the health sensor to be bypassed for a short time.

Display	Programming Instructions
14) HEALTH TIMER *=Next Menu #=Yes	a) Press the #=Yes key to display the health sensor options.
HEALTH TIMER: OFF (2hr, 3hr, 4hr) *=Next #=Accept	b) Press *=Next to select time. c) Press #Accept to set timer.
HEALTH TIMER: 2hrs Accept? *=No #=Yes	d) Press #Yes to start timer.

14) PROGRAM VERSION - Shows the date and version of the E-prom.

Display	Programming Instructions
14) PROGRAM VERSION *=Next Menu #=Yes	a) Press the #=Yes key to view program version.

15) DISPLAY LANGUAGE - Allows the programmer to change the language of all external text; all programming will still be displayed in English.

Display	Programming Instructions
16) DISPLAY LANGUAGE *=Next Menu #=Yes	a) Press the #=Yes key to display the current language.
English *=Scroll "A"=Abort #=Enter	b) Press the "A" key to abort (or exit) menu. • Press #=Enter key to reconfirm English. • Press *=Scroll key to scroll to French, Portuguese, or Spanish press #=Enter key to confirm change.

16) LINE MODE - Line mode will allow the machine to detect a customer line and shortens the vend time (*default is ON*).

Display	Programming Instructions
16) LINE MODE *=Next Menu #=Yes	a) Press the #=Yes key.
LINE MODE: ON *=Scroll "A"=Abort #=Enter	b) Press the "*" key to select the desired option. c) Press the "#" key to confirm the selection.

17) MACHINE SERIAL NUMBER - Program the serial number of the vendor into the computer so that an external data retrieval unit (DEX) can include the serial number when downloading sales information. **NOTE:** Program this feature only if an external data retrieval device will be used.

Display	Programming Instructions
17) MACHINE SERIAL NUMBER *=Next Menu #=Yes	a) Press the #=Yes key. b) Enter serial number of the vendor, found on the outside of door, being sure to add zero(s) if the number is less than six digits. c) Press the #=Enter key to accept.

18) GROUP SALES OPTION - Vend sales can be recorded into 4 different accounts, each with specific vend times. Example: all sales between 7:00 A.M. and 1200 P.M. may be recorded into account "A"; sales between 12:00 P.M. and 2:00 P.M. may be recorded into account "B"; sales after 2:00 P.M. can go into a third account or back into account "A". All information recorded can be obtained by accessing "Sales Meters" once this option has been set.

Note: If a sale occurs outside of a metered block, it will be recorded into the main meter and not into one of the four accounts.

This feature is typically used in locations where commissions are divided based on time of operation. It is also used to record vend activity to determine what the busiest time of day are for a machine.

Display	Programming Instructions
18) GROUP SALES OPTION *=SCROLL A=ABORT #=ENTER	a) Press to the #=Enter key to enter this menu. b) Press the *=Scroll key to move forward.
Day: SUN A=ABT C=CPY D=DEL *=SCRL #=ENTER	c) Press the *=SCRL key to scroll through days of the week. E.G. For Sunday, press #=ENTR key to enter.
SUN BLK 1 ON __: __ *=Abort #=Yes	d) Enter the start of the desired meter time. <i>Note: All times must be listed in military time. If the time is before noon, enter a zero first.</i> e) Press #=Yes key after four digits have been entered.
SUN BLK 1 OFF __: __ *=Abort #=Yes	f) Enter the end of the desired meter time and press the #=Yes key.
GROUP (A-D): A *=Abort #=Enter	g) Press letter of account you wish the sales be recorded into (A, B, C, or D) and press #=Enter key. h) Enter additional blocks of time if desired; if not, press *=Abort key to exit screen. Press "A" key to exit next screen, and "A" once more to return to main menu.

19) TOKENS & COUPONS – Enables the option to accept tokens and coupons.

Display	Programming Instructions
19) TOKENS & COUPONS *=Next D=Back #=Yes	a) Press the #=Yes key.
PROMOTIONS: OFF *=Scroll "A"=Abort #=Enter	b) Press the "*" key to select the desired option. c) Press the "#" key to confirm the selection.

20) FIELD TEST – Enters a diagnostic mode to allow troubleshooting assistance.

Display	Programming Instructions
20) FIELD TEST *=Next D=Back #=Yes	a) Press the #=Yes key.
INPUT MONITOR MK ICE CREAM MACHINE <i>**When INPUT MONITOR is displayed, manually move the robot or trigger home switches to see on the screen that the parts are working properly**</i>	When the display shows INPUT MONITOR, the machine is ready for test. Manually move the robot around and trigger the home switches. The display will show if the computer detects the parts that are being used. Under INPUT MONITOR, the 2-letter abbreviation shows which 24V motors are used in this machine. MK – Merkle-Korff & IG – Igarashi. Press the "#" key to proceed to the next part of the test.

FREE VENDING (TEST)

After programming is complete, it is important to perform a test to make sure that the machine is programmed correctly. By pressing "**Free Vend**" on the Service keypad, the machine will allow menu selections to be vended without money and without affecting the sales meters. To deactivate this feature Press "**Free Vend**" again.

"**Test Vend**" on the service keypad allows money to be inserted in order to test menu selections without affecting sales meters. Money deposited will be returned after each test vend. To deactivate this feature press "**Test Vend**" again.

TROUBLESHOOTING

GLOSSARY OF USEFUL TERMS - Term Definition

- **Vacuum Valve** - An assembly comprised of a valve with a magnetic reed switch that detects airflow and a vacuum seal; used to indicate if the product has been dropped.
- **Controller** - The computer board or VMC
- **Encoder & Encoder Pulses** - A device used to send a given number of pulses per gear rotation which can then be interpreted by software to determine distance and location; allows the controller to calculate position of any bin and product drop point relative to the true home position. Encoders are built into the L/R, F/B, U/D and freezer door motors.
- **Home on the X-axis** The relative home position indicated by the Left/Right home switch trigger located on top of the main beam about ½ way back.
- **Home on the Y-axis** The relative home position indicated by the Front/Back Home Switch located at the front of the main robot beam.
- **Home on the Z-axis** The relative home position indicated by the Up/Down Home Switch; picker head is in the full up position.
- **Home Position or (True) Home Position** - The home coordinate on all axes (X, Y and Z); located at the front left corner of the cabinet.
- **Product Drop Point** - Coordinates where the robot drops product into the product delivery chute; located in the front/center area of the cabinet
- **VAC Error & VAC key** - Log used by the computer to store fatal machine errors. Use the VAC key on the Service Keypad to view the VAC error log. The computer will store the last four fatal errors along with the date and time they occurred.

Fatal Errors & Non-Fatal

- **Errors** - Fatal errors are errors that will put the machine out-of-order. Non-fatal errors will only put a specific bin out-of-order.

Two types of errors:

1. **Non-Fatal Errors** - Once the F820 is programmed and is operating in the field, any
 - **Out Of Product or Bin Load** errors that occur will be displayed on the digital display when the door is opened (Service Mode). These are *localized* errors that put a specific bin out-of-order without taking the machine off line. The customer keypad functions "***= Exit**" and "**#=Next**" can be used to scroll through each error. Out Of Product occurs when the robot reaches the "virtual bottom" of the bin (2 predetermined encoder distances on the Z-axis; one for tall and one for short bins)
 - **Bin Load Error** - Occurs after the robot makes 3 unsuccessful attempts to vend product from a single bin (vacuum seal is lost/product dropped) and puts that bin out-of-order. 9 consecutive, vacuum related Bin Errors become a fatal error: "**Vacuum Out of Order**" (see Fatal Errors). Typically due to robot programming, misalignment, improper loading or using the wrong bin for a product. Use menu option **3) EDIT SELECTION** if a selection needs to be realigned.

*Note: It is important to view all **Out Of Product** and **Bin Load** errors and to check each problem bin by performing a free vend. Do not press "*** Exit**" before viewing all non-fatal errors. To scroll through the list of all bin errors including selection and bin number, use the "**#Next**" key on the customer keypad. Once viewed, these errors can be cleared by pressing "***= Exit**" on the service keypad.

2. Fatal Errors - Errors that put the entire machine out-of-order in order to prevent further component damage. Fatal errors are stored in the VAC log. When the machine is out of order, the error can be displayed by pressing the “#” key. The error history can be viewed by pressing the VAC button on the service keypad while in Service Mode. The digital display will list up to 4 VAC errors.

- **Left/Right (L/R) Stuck Motor** Occurs when the robot tries to home itself on the X-axis and times out before triggering the L/R Home Switch.
- **Front Back (F/B) Stuck Motor** Occurs when the robot tries to home itself on the Y-axis and times out before triggering the F/B Home Switch.
- **Up/Down (U/D) Stuck Motor** Occurs when the robot tries to home itself on the Z-axis and times out before triggering the U/D Home Switch.
- **Left/Right (L/R) Encoder Error** Occurs when the controller fails to see encoder pulses on the X-axis after 3 unsuccessful tries. This error typically occurs during product retrieval or delivery.
- **Front Back (F/B) Encoder Error** Occurs when the controller fails to see encoder pulses on the Y-axis after 3 unsuccessful tries. This error typically occurs during product retrieval or delivery.
- **Up/Down (U/D) Encoder Error** Occurs immediately after the controller does not see encoder pulses on the Z-axis on the way down to the bin.
- **Vacuum Out Of Order** Occurs when the robot makes 3 unsuccessful attempts to vend product on 3 consecutive bins (9 consecutive Bin Errors= Vacuum Out of Order).
- **Out Of Product** Occurs when the robot reaches the “Virtual Bottom” of every bin or selection in the entire machine indicating that there is no product.

*Only one Fatal Error is logged in the VAC for any given vend cycle. The Fatal Error that initially puts the machine out of order is generally the error that is logged and displayed in the VAC (exception: Stuck Motor Errors will take precedence over Encoder Errors).

ORDER OF OPERATION - VEND CYCLE

1. Initiating The Vend Cycle -

Credits are calculated, registered and displayed. Freezer door raises to its full open position

- The controller board verifies that the freezer door is truly closed by monitoring both the open and closed freezer door switches.
- The controller board activates the motor in the freezer door lift assembly opening the lid. When the freezer lid reaches the open position, the freezer door open switch is activated.
- **A selection is accepted from the customer keypad.**
- **Vend cycle starts from the Home Position or the Drop Point.**

2. Robot Carriage Moves Back -

The F/B Motor moves the robot carriage back on the Y-axis.

As the robot leaves the F/B Home Position, the controller looks for the F/B Home Switch to open to begin counting encoder pulses relayed by the F/B Encoder Switch.

If: Encoder pulses are not seen for a period of time, the robot will attempt to return to the Home Position.

- The robot moves to the Home Position on the X-axis then the Y-axis.
- The customer is prompted: "Make Another Selection".
- The next vend cycle starts from the Home position
- The robot has 3 consecutive failed attempts at vending any selection(s)
- The machine is put out-of-order with a F/B Encoder Error
- Encoder pulses are not seen for a period of time and the robot times out before reaching the Home Position.
- The machine is put out-of-order with a F/B Stuck Motor

The robot stops once it reaches the selection's Y-coordinate.

3. Robot Moves Right -

The L/R Motor moves the robot to the right on the X-axis,

As the robot leaves the L/R Home position, the controller looks for the L/R Home Switch to open to begin counting encoder pulses relayed by the L/R Encoder Switch.

If: Encoder pulses are not seen for a period of time, the robot will attempt to return to the Home Position.

- The robot moves to the Home Position on the Y-axis then the X-axis.
- The customer is prompted: "Make Another Selection".
- The next vend cycle starts from the Home position

The robot has 3 consecutive failed attempts at vending any selection(s)

- The machine is put out-of-order with a L/R Encoder Error

Encoder pulses are not seen for a period of time and the robot times out before reaching the Home Position.

- The machine is put out-of-order with a L/R Stuck Motor

The robot stops once it reaches the selection's X-coordinate.

4. Picker Head Moves Down (Robot Is Over The Bin)

The U/D Motor moves the picker head down the Z-axis.

As the robot leaves the U/D Home position, the controller looks for the U/D Home Switch to open to begin counting encoder pulses relayed by the U/D Encoder Switch.

If: Encoder pulses are not seen for a period of time, the robot will attempt to return to the Home Position.

- The robot moves to the Home Position on the Z-axis, the Y-axis then the X-axis.
- The customer is prompted: "Make Another Selection".
- The next vend cycle starts from the Home position

The robot has 3 consecutive failed attempts at vending any selection(s)

- The machine is put out-of-order with an U/D Encoder Error

Encoder pulses are not seen for a period of time and the robot times out before reaching

the Home Position.

- The machine is put out-of-order with a U/D Stuck Motor

The controller monitors for an open signal from the product sensor (signifying contact with product), and stops the U/D Motor from lowering the picker head.

If: The controller does not detect the product sensor, the U/D Motor will continue to lower the picker head and unreal the hose.

- The controller counts encoder pulses on the way down to determine how far it is from the virtual "bin bottom"
- If the virtual "bin bottom" Z-coordinate is reached, the robot will return to the Home Position.
- The bin is put out-of-order with an Out Of Product Error.
- The customer is prompted: "Make Another Selection".
- If all bins in the machine are out of product, the machine will be put out-of-order with an Out Of Product error.

5. Vacuum Motor turns on.

The flap in the airflow box rises to the up position, closing the reed switch. Once a seal has been created with the product the flap drops down, opening the switch.

If: The product falls off, the airflow in the hose causes the flap to rise to its up position closing the reed switch. This signals the computer board to go "home" and retry the vend attempt.

- Three failed attempts disable the bin with a Bin Load Error.
- Nine consecutive attempts put the machine out of order with Vacuum Out Of Order.

The open reed switch indicates that the robot has product.

6. Picker Head Moves Up

The controller activates the U/D Motor, lifting the picker head up the Z-axis (after a 1 sec. delay)

The robot reaches the full up position triggering the Z-Home Switch.

If: The controller times out before a closed U/D Home Switch signal is detected.

- The vacuum motor is shut down.
- The machine is put out-of-order with an UD Motor Stuck Error.

The controller monitors for a closed reed switch in the vacuum valve assembly, indicating a dropped product (airflow box flap in the up position caused by a break in the vacuum seal).

If: Product is dropped, the robot returns to the Z-axis home position and reattempts to complete the vend cycle up to 3 times.

- The robot will go to the home position before making the third attempt.
- 3 unsuccessful attempts will put the bin out-of-order with a Bin Error.
- The customer is prompted: "Make Another Selection".
- The machine is put out-of-order with a Vacuum Out Of Order Error, after 9 consecutive vacuum errors (3 bin errors).

7. Robot Moves Left/Right (Robot Is Centered In Cabinet)

The L/R motor moves the robot left or right towards the center of the cabinet (calculated Product Drop Point coordinate on the X-axis).

If: The bin location is located near the gusset zone (front left and right corners of the cabinet), the robot will move back a default distance before continuing on the X-axis.

The controller counts encoder pulses relayed by the L/R Encoder Switch.

If: Encoder pulses are not seen for a period of time, the robot will attempt to return to the Home Position.

- The robot moves to the Home Position on the Y-axis then the X-axis.
- The customer is prompted: "Make Another Selection".
- The next vend cycle starts from the Home Position.

The robot has 3 consecutive failed attempts at vending any selection(s)

- The machine is put out-of-order with a L/R Encoder Error.

The controller monitors for a closed reed switch indicating dropped product (airflow box flap in the up position caused by a break in the vacuum seal).

If: Product is dropped, the robot returns to the X-Y encoder position and reattempts to complete the vend cycle up to 3 times.

- The robot will return to the bin and try to pick up product.
- 3 unsuccessful attempts put the bin out-of-order with a Bin Error.
- The customer is prompted: "Make Another Selection".
- The machine is put out-of-order with a Vacuum Out Of Order Error, after 9 consecutive vacuum errors (3 bin errors).

The robot stops once it reaches the calculated Product Drop Point coordinate on the X-axis.

8. Robot Carriage Moves Forward

The F/B Motor moves the robot towards the F/B Home Position on the Y-axis.

The controller monitors for a closed reed switch in the vacuum valve assembly, indicating dropped product (airflow box flap in the up position caused by a break in the vacuum seal).

If: Product is dropped, the robot returns to the X-Y encoder position and reattempts to complete the vend cycle up to 3 times.

- The robot will return to the bin and try to pick up product.
- 3 unsuccessful attempts will put the bin out-of-order with a Bin Error.
- The customer is prompted: "Make Another Selection".
- The machine is put out-of-order with a Vacuum Out Of Order Error, after 9 consecutive vacuum errors (3 bin errors).

As the carriage activates and moves past the F/B home switch, the controller board begins to count encoder pulses calculating the location of the product drop point

If: Encoder pulses are not seen for a period of time, the robot will move straight back, returning to the Y-Home Position located at the front of the cabinet.

- The robot will retry to deliver product up to 3 times in a row.

The robot has 3 unsuccessful attempts at reaching the drop point and completing the vend cycle.

- The machine is put out-of-order with a F/B Encoder Error.

Before reaching the Product Drop Point, the robot carriage mechanically triggers the blow off valve crank, releasing the vacuum pressure from the system and dropping the product into the delivery chute.

The robot stops once it reaches the calculated Product Drop Point coordinate on the Y-axis (approx. 5 1/2 " beyond F/B Home Position).

The controller turns off the Vacuum Motor

9. The Vend Cycle Is Complete (The Machine Is Ready For Another Vend)

Any change owed to the customer is calculated and dispensed.

If no more vends are made within the allotted time, the controller board verifies an open freezer door switch then activates the motor in the freezer door lift assembly to close the lid.

The freezer lid reaches the closed position activating the freezer door closed switch.

The vend sequence is complete and the machine is ready for another vend.

The next three vend cycles will be initiated from this drop point position.

The robot typically returns to true home after every 4 vends to reorient itself for accuracy. To improve accuracy when dealing with small vend items, the virtual home may be set to one. To do this go to menu item 14) PROGRAM VERSION, press the "#" key. Then press "LOAD". The display will show virtual home count 04. Press 01 and "#" to accept. The robot will now home after every vend.

TROUBLESHOOTING LOGIC / CHARTS

Always troubleshoot using logical, progressive steps so that the maintenance and repair procedure runs smoothly and efficiently. Most failures may have minor causes such as loose connectors or dirty contacts. Always check the following before replacing any parts:

- **Check that all the plugs and connections are seated firmly in their receptacles.**
- **Check that there is continuity in the wires.**
- **Check that the connector pins are not bent or broken.**

Problem	Possible Cause	Corrective Action
<p>Note: The machine has dynamic breaking features that make it difficult to move the robot manually when power is on.</p>		
<p>Left/Right Stuck Motor</p> <p>Turn machine power off. Manually move the robot right about 6". Turn power on. If the robot moves left:</p>	<p>Faulty L/R home switch</p>	<p>Turn the power off. Disconnect the left / right home switch. Using a jumper wire or small paperclip connect the two wires that the switch plugs into. Move the robot 6" to the right. Turn power on. If the robot does not move replace the left / right home switch. PN-49500566.</p>
	<p>Check the connection from the controller board to the L/R home switch.</p>	<p>Turn power off. Check the computer board connection labeled J5 and intermediate board connections J5 and J24. If the connections look good check continuity from computer board J5 pins 7 & 8 to int. board J5 pins 7 & 8, and from int. board J24 pins 1 & 2 to the two wires at the left / right home switch.</p>
	<p>Faulty computer board / intermediate board</p> <p><i>When replacing the computer board note the software on the defective board as well as the position of the jumper JP1. Make sure the software and jumper position are the same. Incorrect software or jumper may cause the machine to function improperly.</i></p>	<p>Turn power off. Locate the computer board connection labeled J5. Using a jumper wire or small paperclip, connect pins 7 & 8 together through the back of the connector. Move the robot right 6" and turn the power on. If the robot moves left, replace the computer board. PN-19300529. If the robot does not move left replace the intermediate board. PN-49405540.</p>
<p>Left/Right Stuck Motor</p> <p>Turn machine power off. Manually move the robot right about 6". Turn power on. If the robot does not move left:</p>	<p>Broken / binding gear</p>	<p>Turn power off. Examine the left / right motor gear. Look for any broken teeth. Manually move the robot left and right. Check for binding. If a replacement gear is necessary, PN-49500406.</p>

Problem	Possible Cause	Corrective Action
L/R Stuck Motor (cont.)	Check connection from the Computer board to the L/R Motor.	Turn power off. Check the computer board connection labeled J18, the intermediate board connections J18 and J30 and the plug at the left / right motor. If the connections look good check continuity from computer board J18 pins 10 & 12 to int. board J18 pins 10 & 12, and from int. board J30 pins 1 & 5 to the left / right motor connector pins 1 & 5.
	Faulty intermediate board	Turn power off. Remove the connectors from J18 and J30 on the intermediate board. At J18 inspect pins 10 & 12, and at J30 pins 1 & 5. Repair or straighten any damaged pins. If any pins are loose, replace the intermediate board. PN-49405540.
	Faulty left / right motor	Replace the L/R motor. If the motor has a small pigtail harness use PN-49505565. If the connector is right on the motor use PN-49505555.
	Faulty computer board <i>When replacing the computer board note the software on the defective board as well as the position of the jumper JP1. Make sure the software and jumper position are the same. Incorrect software or jumper may cause the machine to function improperly.</i>	Replace the computer board PN-19300529.
F/B Stuck Motor Turn machine power off. Manually move the robot back about 6". Turn power on. If the robot moves forward:	Faulty F/B home switch	Turn the power off. Disconnect the front / back home switch. Using a jumper wire or small paperclip connect the two wires that the switch plugs into. Move the robot back 6". Turn power on. If the robot does not move replace the front / back home switch. PN-49500566.
	Check connection from the controller board to the F/B home switch.	Turn power off. Check the computer board connection labeled J10 and intermediate board connections J10 and J24. If the connections look good check continuity from computer board J10 pins 5 & 6 to int. board J10 pins 5 & 6, and from int. board J24 pins 4 & 5 to the two wires at the front / back home switch.

Problem	Possible Cause	Corrective Action
F/B Stuck Motor (cont.) Robot moves:	Faulty computer board / intermediate board <i>When replacing the computer board note the software on the defective board as well as the position of the jumper JP1. Make sure the software and jumper position are the same. Incorrect software or jumper may cause the machine to function improperly.</i>	Turn power off. Locate the computer board connection labeled J10. Using a jumper wire or small paperclip, connect pins 5 & 6 together through the back of the connector. Move the robot back 6" and turn the power on. If the robot moves forward, replace the computer board. PN-19300529. If the robot does not move forward replace the intermediate board. PN-49405540.
F/B Stuck Motor Turn machine power off. Manually move the robot back about 6". Turn power on. If the robot does not move forward:	Broken / binding gear	Turn power off. Examine the front / back motor gear. Look for any broken teeth. Manually move the robot front to back. Check for binding. If a replacement gear is necessary, PN-49500406.
	Check connection from the Computer board to the F/B Motor.	Turn power off. Check the computer board connection labeled J18, the intermediate board connections J18 and J29 and the plug at the front / back motor. If the connections look good check continuity from computer board J18 pins 7 & 9 to int. board J18 pins 7 & 9, and from int. board J29 pins 1 & 5 to the front / back motor connector pins 1 & 5.
	Faulty intermediate board	Turn power off. Remove the connectors from J18 and J29 on the intermediate board. At J18 inspect pins 7 & 9, and at J29 pins 1 & 5. Repair or straighten any damaged pins. If any pins are loose, replace the intermediate board. PN-49405540.
	Faulty front / back motor	Replace the F/B motor. If the motor has a small pigtail harness use PN-49505565. If the connector is right on the motor use PN-49505555.
	Faulty computer board <i>When replacing the computer board note the software on the defective board as well as the position of the jumper JP1. Make sure the software and jumper position are the same. Incorrect software or jumper may cause the machine to function improperly.</i>	Replace the computer board PN-19300529.

Problem	Possible Cause	Corrective Action
<p>U/D Stuck Motor</p> <p>Turn machine power off. Manually move the robot hose down about 6". Turn power on. If the robot hose moves up:</p>	<p>Faulty U/D home switch</p>	<p>Turn the power off. Disconnect the up / down home switch. Using a jumper wire or small paperclip connect the two wires that the switch plugs into. Move the robot down 6". Turn power on. If the robot does not move replace the up / down home switch. PN-49500566.</p>
	<p>Check connection from the controller board to the U/D home switch.</p>	<p>Turn power off. Check the computer board connection labeled J5 and intermediate board connections J5 and J26. If the connections look good check continuity from computer board J5 pins 3 & 4 to int. board J5 pins 3 & 4, and from int. board J26 pins 1 & 2 to the two wires at the up / down home switch.</p>
	<p>Faulty computer board / intermediate board</p> <p><i>When replacing the computer board note the software on the defective board as well as the position of the jumper JP1. Make sure the software and jumper position are the same. Incorrect software or jumper may cause the machine to function improperly.</i></p>	<p>Turn power off. Locate the computer board connection labeled J5. Using a jumper wire or small paperclip, connect pins 3 & 4 together through the back of the connector. Move the robot hose down 6" and turn the power on. If the robot hose moves up, replace the computer board. PN-19300529. If the robot hose does not move up replace the intermediate board. PN-49405540.</p>
<p>U/D Stuck Motor</p> <p>Turn machine power off. Manually move the robot hose down about 6". Turn power on. If the robot hose does not move up:</p>	<p>Broken / binding gear</p>	<p>Turn power off. Examine the up / down motor gears. Look for any broken teeth. Manually move the robot hose up and down. Check for binding. If a replacement gear is necessary, PN-49500404 – Drive gear (large) and PN-49500405 – Driven gear (small).</p>
	<p>Check connection from the Computer board to the U/D Motor.</p>	<p>Turn power off. Check the computer board connection labeled J18, the intermediate board connections J18 and J27 and the plug at the up / down motor. If the connections look good check continuity from computer board J18 pins 4 & 6 to int. board J18 pins 4 & 6, and from int. board J27 pins 1 & 5 to the up / down motor connector pins 1 & 5.</p>

Problem	Possible Cause	Corrective Action
U/D Stuck Motor (cont.)	Faulty intermediate board	Turn power off. Remove the connectors from J18 and J27 on the intermediate board. At J18 inspect pins 4 & 6, and at J27 pins 1 & 5. Repair or straighten any damaged pins. If any pins are loose, replace the intermediate board. PN-49405540.
	Faulty up / down motor	Replace the U/D motor. If the motor has a small pigtail harness use PN-49505565. If the connector is right on the motor use PN-49505555.
	Faulty computer board <i>When replacing the computer board note the software on the defective board as well as the position of the jumper JP1. Make sure the software and jumper position are the same. Incorrect software or jumper may cause the machine to function improperly.</i>	Replace the computer board PN-19300529.

Freezer Stuck Closed If the freezer does open and closes immediately.	Faulty freezer door open switch	Turn the power off. Disconnect the freezer door open switch. Using a jumper wire or small paperclip connect the two wires that the switch plugs into. Close the freezer door. Turn power on and press "Load". If the freezer door does not open replace the freezer door open switch. PN-49500566.
	Improper alignment of the freezer open trigger.	On the bottom of the freezer door lift arm is a small metal ramp (trigger). If the trigger is not aligned properly, it will miss the arm of the door open switch. Check the alignment to the switch and adjust if necessary.
	Check connection from the controller board to the freezer door open switch.	Turn power off. Check the computer board connection labeled J10 and intermediate board connections J10 and J23. If the connections look good check continuity from computer board J10 pins 9 & 10 to int. board J10 pins 9 & 10, and from int. board J23 pins 4 & 5 to the two wires at the freezer door open switch.

<p>Freezer Stuck Closed (cont.)</p> <p>Freezer opens.</p>	<p>Faulty computer board / intermediate board</p> <p><i>When replacing the computer board note the software on the defective board as well as the position of the jumper JP1. Make sure the software and jumper position are the same. Incorrect software or jumper may cause the machine to function improperly.</i></p>	<p>Turn power off. Locate the computer board connection labeled J10. Using a jumper wire or small paperclip, connect pins 9 & 10 together through the back of the connector. Close the freezer door, turn the power on and press "Load". If the freezer door opens, replace the computer board. PN-19300529. If the freezer door does not open replace the intermediate board. PN-49405540.</p>
<p>Freezer Stuck Closed</p> <p>If the freezer does not open.</p>	<p>Broken / binding gear</p>	<p>Turn power off. Examine the freezer door lift motor gears. Look for any broken teeth. Manually move the lift arm up and down. Check for binding. If a replacement gear is necessary, PN-49500406.</p>
	<p>Check connection from the Computer board to the Freezer Door Motor.</p>	<p>Turn power off. Check the computer board connection labeled J18, the intermediate board connections J18 and J25 and the plug at the freezer door motor. If the connections look good check continuity from computer board J18 pins 1 & 3 to int. board J18 pins 1 & 3, and from int. board J25 pins 1 & 5 to the freezer door motor connector pins 1 & 5.</p>
	<p>Faulty intermediate board</p>	<p>Turn power off. Remove the connectors from J18 and J25 on the intermediate board. At J18 inspect pins 1 & 3, and at J25 pins 1 & 5. Repair or straighten any damaged pins. If any pins are loose, replace the intermediate board. PN-49405540.</p>
	<p>Faulty freezer door motor</p>	<p>Replace the freezer door motor. If the motor has a small pigtail harness use PN-49505565. If the connector is right on the motor use PN-49505555.</p>

<p>Freezer Stuck Closed (cont.)</p> <p>If the freezer does not open.</p>	<p>Faulty computer board / intermediate board</p> <p><i>When replacing the computer board note the software on the defective board as well as the position of the jumper JP1. Make sure the software and jumper position are the same. Incorrect software or jumper may cause the machine to function improperly.</i></p>	<p>Replace the computer board PN-19300529.</p>
<p>Freezer Stuck Open</p> <p>If the freezer is closed.</p>	<p>Faulty freezer door closed switch</p>	<p>Turn the power off. Disconnect the freezer door closed switch. Using a jumper wire or small paperclip connect the two wires that the switch plugs into. Turn power on. If the error message does not show again replace the freezer door closed switch. PN-49500566.</p>
	<p>Improper alignment of the freezer closed switch.</p>	<p>On the left cabinet wall in front of the freezer lid is the freezer door closed switch. If the switch is not aligned properly the trigger on the freezer lid will not reach it enough to fully press the switch. Loosen the screws on the switch, slide it back towards the freezer and retighten.</p>
	<p>Check connection from the controller board to the freezer door closed switch.</p>	<p>Turn power off. Check the computer board connection labeled J10 and intermediate board connections J10 and J23. If the connections look good check continuity from computer board J10 pins 7 & 8 to int. board J10 pins 7 & 8, and from int. board J23 pins 1 & 2 to the two wires at the freezer door closed switch.</p>
	<p>Faulty computer board / intermediate board</p> <p><i>When replacing the computer board note the software on the defective board as well as the position of the jumper JP1. Make sure the software and jumper position are the same. Incorrect software or jumper may cause the machine to function improperly.</i></p>	<p>Turn power off. Locate the computer board connection labeled J10. Using a jumper wire or small paperclip, connect pins 7 & 8 together through the back of the connector. Turn the power on. If the display shows “Freezer stuck open”, replace the intermediate board. PN-49405540. If the display does not show “Freezer stuck open”, replace the computer board PN-19300529.</p>

Freezer Stuck Open If the freezer is open.	Broken / binding gear	Turn power off. Examine the freezer door lift motor gears. Look for any broken teeth. Manually move the lift arm up and down. Check for binding. If a replacement gear is necessary, PN-49500406.
	Robot interference	If the robot has had an error and could not return home, it may be in the way of the freezer door. If this happens, move the robot, close the freezer door and make a vend attempt. If the machine fails, it should provide a different error. See troubleshooting for that error.
	Improper alignment of the freezer lift assy.	If the freezer lift assy is not aligned properly it can bind going either up or down jamming the door.
	Check connection from the Computer board to the Freezer Door Motor.	Turn power off. Check the computer board connection labeled J18, the intermediate board connections J18 and J25 and the plug at the freezer door motor. If the connections look good check continuity from computer board J18 pins 1 & 3 to int. board J18 pins 1 & 3, and from int. board J25 pins 1 & 5 to the freezer door motor connector pins 1 & 5.
	Faulty intermediate board	Turn power off. Remove the connectors from J18 and J25 on the intermediate board. At J18 inspect pins 1 & 3, and at J25 pins 1 & 5. Repair or straighten any damaged pins. If any pins are loose, replace the intermediate board. PN-49405540.
	Faulty freezer door motor	Replace the freezer door motor. If the motor has a small pigtail harness use PN-49505565. If the connector is right on the motor use PN-49505555.
	Faulty computer board / intermediate board <i>When replacing the computer board note the software on the defective board as well as the position of the jumper JP1. Make sure the software and jumper position are the same. Incorrect software or jumper may cause the machine to function improperly.</i>	Replace the computer board PN-19300529.

<p>L/R Encoder Error</p> <p>During the vend cycle, the robot moves to the right about 2" then returns home. Display reads "Select Another". Three failed attempts result in this error.</p>	<p>Check connection from the controller board to the L/R encoder switch.</p>	<p>Turn power off. Check the computer board connection labeled J5, the intermediate board connections J5 and J30 and the plug at the left / right motor. If the connections look good check continuity from computer board J5 pins 15, 16 & 17 to int. board J5 pins 15, 16 & 17, and from int. board J30 pins 2, 3 & 4 to the left / right motor connector pins 2, 3 & 4.</p>
	<p>Faulty encoder switch in the L/R motor.</p>	<p>Set your multi-meter to DC Volts. On the intermediate board, connector J30 across pins 2 & 3 should be 5 volts. Across pins 3 & 4 should fluctuate between 0v and 5v as you slide the robot left to right. If not replace the L/R motor. If the motor has a small pigtail harness use PN-49505565. If the connector is right on the motor use PN-49505555.</p>
	<p>Faulty intermediate board / faulty computer board</p> <p><i>When replacing the computer board note the software on the defective board as well as the position of the jumper JP1. Make sure the software and jumper position are the same. Incorrect software or jumper may cause the machine to function improperly.</i></p>	<p>Set your multi-meter to DC Volts. On the computer board, connector J5 across pins 15 & 16 should be 5 volts. Across pins 16 & 17 should fluctuate between 0v and 5v as you slide the robot left to right. If not replace the intermediate board. PN-49405540. If the pulse is seen replace the computer board PN-19300529.</p>
<p>F/B Encoder Error</p> <p>During the vend cycle, the robot moves to the back about 2" then returns home. Display reads "Select Another". Three failed attempts result in this error.</p>	<p>Check connection from the controller board to the F/B encoder switch.</p>	<p>Turn power off. Check the computer board connection labeled J5, the intermediate board connections J5 and J29 and the plug at the front / back motor. If the connections look good check continuity from computer board J5 pins 12, 13 & 14 to int. board J5 pins 12, 13 & 14, and from int. board J29 pins 2, 3 & 4 to the front / back motor connector pins 2, 3 & 4.</p>
	<p>Faulty encoder switch in the F/B motor.</p>	<p>Set your multi-meter to DC Volts. On the intermediate board, connector J29 across pins 2 & 3 should be 5 volts. Across pins 3 & 4 should fluctuate between 0v and 5v as you slide the robot front to back. If not replace the F/B motor. If the motor has a small pigtail harness use PN-49505565. If the connector is right on the motor use PN-49505555.</p>

<p>F/B Encoder Error (cont.)</p>	<p>Faulty intermediate board / faulty computer board</p> <p><i>When replacing the computer board note the software on the defective board as well as the position of the jumper JP1. Make sure the software and jumper position are the same. Incorrect software or jumper may cause the machine to function improperly.</i></p>	<p>Set your multi-meter to DC Volts. On the computer board, connector J5 across pins 12 & 13 should be 5 volts. Across pins 13 & 14 should fluctuate between 0v and 5v as you slide the robot front / back. If not replace the intermediate board. PN-49405540. If the pulse is seen replace the computer board PN-19300529.</p>
<p>U/D Encoder Error</p> <p>During the vend cycle, the robot hose moves down about 2" then returns home. Display reads "Select Another". Three failed attempts result in this error.</p>	<p>Check connection from the controller board to the U/D encoder switch.</p>	<p>Turn power off. Check the computer board connection labeled J5, the intermediate board connections J5 and J27 and the plug at the up / down motor. If the connections look good check continuity from computer board J5 pins 9, 10 & 11 to int. board J5 pins 9, 10 & 11, and from int. board J27 pins 2, 3 & 4 to the front / back motor connector pins 2, 3 & 4.</p>
	<p>Faulty encoder switch in the U/D motor.</p>	<p>Set your multi-meter to DC Volts. On the intermediate board, connector J27 across pins 2 & 3 should be 5 volts. Across pins 3 & 4 should fluctuate between 0v and 5v as you slide the robot up and down. If not replace the U/D motor.</p> <p>If the motor has a small pigtail harness use PN-49505565. If the connector is right on the motor use PN-49505555.</p>
	<p>Faulty intermediate board / faulty computer board</p> <p><i>When replacing the computer board note the software on the defective board as well as the position of the jumper JP1. Make sure the software and jumper position are the same. Incorrect software or jumper may cause the machine to function improperly.</i></p>	<p>Set your multi-meter to DC Volts. On the computer board, connector J5 across pins 9 & 10 should be 5 volts. Across pins 10 & 11 should fluctuate between 0v and 5v as you slide the robot hose up and down. If not replace the intermediate board. PN-49405540. If the pulse is seen replace the computer board PN-19300529.</p>
<p>Out Of Product Product still in bins</p>	<p>Tall bin was programmed as a short bin.</p>	<p>Reprogram and edit selection.</p>
	<p>Out of Product</p>	<p>Refill</p>
	<p>Robot may be hitting the edge of the bin causing misreading of distance travelled.</p>	<p>Edit programmed location of the affected bin.</p>
<p>Vacuum Out Of Order</p> <p>Vacuum turns on.</p>	<p>Not enough voltage going to machine to pick up product.</p>	<p>Plug into better outlet or unplug anything that may be sharing the same outlet.</p>
	<p>Hole in hose</p>	<p>Locate and patch the hole with electrical tape or replace the damaged hose. Picker hose (130") PN-49200130.</p>

Vacuum Out Of Order (cont.) Vacuum turns on.	Faulty product sensor.	If the picker tip is making contact with product and not stopping it may not see the product sensor. Disconnect the tie wrap and remove the hose from the picker. Unplug the two-pin connection and check both connectors and their pins for damage. Check the end with the two male pins for continuity between them, there should be none. Press the product sensor lever up, the pins should now have continuity. If not, replace the product sensor switch. PN-39500567.
	Check connection from the picker tip to the computer board.	Turn power off. Check the computer board connection labeled J10, the intermediate board connections J10 and J21 and the plug at the product sensor switch. If the connections look good check continuity from computer board J10 pins 1 & 2 to int. board J10 pins 1 & 2, and from int. board J21 pins 1 & 2 to the product sensor switch connector pins 1 & 2.
	Faulty intermediate board / faulty computer board <i>When replacing the computer board note the software on the defective board as well as the position of the jumper JP1. Make sure the software and jumper position are the same. Incorrect software or jumper may cause the machine to function improperly.</i>	On the computer board connector J10 use a jumper wire or small paperclip to connect pins 1 & 2 together. Make a vend attempt. If the picker drops to the product replace the computer board PN-19300529. If the picker does not drop to the product replace the intermediate board PN-49405540.
	Improper programming	If the picker is hitting the bin or anywhere but in the product center, go to menu option 3) Edit Selection and edit the drop location.
Vacuum Out Of Order Vacuum does not turn on.	Blown vacuum breaker	Check the front of the main power box for the vacuum breaker (10A). Reset if necessary.
	Check connection from the computer board to triac board.	Turn power off. Check the computer board connection J4 and the connections on the single triac board on the main power box. If the connections look good check continuity from computer J4 to triac board connector JP1.
	Faulty vacuum motor	Replace vacuum motor

Vacuum Out Of Order (cont.) Vacuum does not turn on.	Faulty computer board	Turn power off. On the computer board connector J4, use a small jumper wire or paperclip and connect pins 12 and 7 through the back of the connector. Turn the power on. If the vacuum turns on replace the computer board.
	<i>When replacing the computer board note the software on the defective board as well as the position of the jumper JP1. Make sure the software and jumper position are the same. Incorrect software or jumper may cause the machine to function improperly.</i>	
	Blown fuse	Check the fuse on the triac board, replace if necessary. If the fuse continuously blows replace the triac board PN-49905560.
	Faulty single triac board	Replace the single triac board PN-49905560.
Bin Errors Robot dropping product	Programming and/or bin alignment.	Check & edit the affected bins so robot drops straight to the center of the product.
	Misshapen or hole in Picker tip	Replace picker tip
	Machine not level so the Picker head is not centered on product causing improper seal.	Level machine.
	Leaking vacuum valve assy	Inspect the assembly and fix the cause of the leak.
	Binding in the vacuum valve assembly	Inspect the assembly and fix the cause of the binding.
False Vend Robot drops down approx 5", comes up without getting product & proceeds to product drop point to complete vend cycle. Acts as if there was a successful vend cycle.	Blockage or obstruction anywhere between picker tip and vacuum valve assembly.	Disconnect hose and look for obstruction. Also check picker tip, picker assy, and the vacuum valve box assy.
	Faulty reed switch	On top of the vacuum valve box is a magnetic reed switch. Disconnect the two pin connector at the end of the switch. Check continuity across the two pins. If there is continuity replace the switch. PN-19900518.
	Check connection from controller board to vacuum switch.	Check continuity from the vacuum switch (on the vac valve box) to the intermediate board J28, and from the intermediate board J5 pins 5 & 6 to the computer board J5 pins 5 & 6.
	Faulty intermediate board	Disconnect intermediate connector J5 and J28. check continuity across the two pins at J28. If there is continuity replace the intermediate board PN-49405540.

<p>False Vend (cont.)</p>	<p>Faulty computer board</p> <p><i>When replacing the computer board note the software on the defective board as well as the position of the jumper JP1. Make sure the software and jumper position are the same. Incorrect software or jumper may cause the machine to function improperly.</i></p>	<p>Disconnect the J5 connector from the computer board. Check continuity across pins 5 & 6. If there is continuity replace the computer board PN-19300529.</p>
<p>Product Sensor Error</p> <p>This error occurs when the computer receives a signal that a product has been contacted before the hose drops.</p>	<p>Obstruction in picker assy</p>	<p>Check the picker assembly and the activating lever for any gummy materials or binding to the lever. If any of this is present, the lever cannot drop properly causing it to stay up on the product sensor switch.</p>
	<p>Faulty product sensor switch</p>	<p>Remove machine power. Disconnect the hose from the picker. Unplug the 2-pin connector. Check continuity on the male pins. If there is continuity across the male pins replace the picker head assembly. PN-39510620.</p>
	<p>Short in the harness from the picker to the intermediate board.</p>	<p>Remove machine power. Disconnect the hose from the picker. Unplug the 2-pin connector. Unplug the intermediate board connector labeled J21. Check continuity on the two harness pins. If there is replace the harness. PN-49500532.</p>
	<p>Faulty intermediate board</p>	<p>Remove machine power. Disconnect intermediate board connectors J21 and J10. Check continuity on the J21 pins. If there is replace the intermediate board. PN-49405540.</p>
	<p>Faulty computer board</p> <p><i>When replacing the computer board note the software on the defective board as well as the position of the jumper JP1. Make sure the software and jumper position are the same. Incorrect software or jumper may cause the machine to function improperly.</i></p>	<p>Unplug computer board connector J10. Check for continuity on the board at J10 pins 1 & 2. If there is replace the computer board. PN-19300529.</p>

<p>Health Sensor Active</p> <p>Occurs when the health sensor opens. Usually at +10 degrees.</p>	<p>Double-check the freezer temperature.</p>	<p>If the temperature is above +10, adjust the thermostat. It is located over the back right corner of the freezer. Turn the adjustment screw clockwise to make the temperature colder.</p>
	<p>Faulty health sensor</p>	<p>With the power off, unplug the connector on the intermediate board labeled J22. check continuity on the two harness wires. If there is none, and <i>if the freezer temp is below -10</i>, replace the health sensor. PN-19610510.</p>
	<p>Faulty intermediate board / faulty computer board</p> <p><i>When replacing the computer board note the software on the defective board as well as the position of the jumper JP1. Make sure the software and jumper position are the same. Incorrect software or jumper may cause the machine to function improperly.</i></p>	<p>Disconnect the intermediate board connectors J22 and J10. Check continuity across the pins at J22. Also look for bent pins. If there is continuity replace the intermediate board. PN-49405540. Otherwise replace the computer board. PN-19300529.</p>

REMOVING CONSOLE

Tools required: 1/4" nut driver, 3/8" and 7/16" sockets and ratchet

PURPOSE: Getting the machine through narrow doorways.

- 1) Remove the cover from the computer board located on the top of the console either by a) loosening (3) 1/4" headed screws and lifting the cover up and off; then remove (1) of the (2) bolts (3/8" head) holding the top of the console onto the cabinet; or by b) removing the top (2) bolts (3/8" head) and loosening the bottom (1/4" head) bolt, then lift the cover up and off, then, reinstall (1) of the bolts (3/8" head). We want to leave (1) of the bolts in place just to prevent the console from coming off before we are ready.
- 2) With a permanent marker, number each of the FFC cables and put a similar number adjacent to each cable on the board. Similarly, mark the 2 pin connectors, which plug onto the interface board at J28 (vac sensor, below the ground wire), the 2-pin connector at J22 (health sensor) and the 2-pin connector at J21 (picker tip). Remove all cables and the 2 pin connectors from the interface board.
- 3) Label and remove the following connectors from the computer board: a) door (2 pin, top left, twisted wires); b) triacs (left side lower, 12 pin w/wires at location 1 and 12 only); c) power (4 pin, bottom left); d) MDB (J11, 6 pin, right side, middle, white connector/white wires.
- 4) Remove coin box (below console) and remove the (2) bolts (3/8" heads and 7/16" nuts) holding the console on to the bottom of the cabinet.
- 5) Pull the cables and wires through the holes in the console and out the back, then, remove the wiring harness from the retainers on the back of the console. Cut tie wraps as necessary making note of their location so that they can be accurately replaced when reassembling the console.
- 6) Loosen the (3) bolts that hold the back of the console to the side of the cabinet. These holes are slotted so the bolts don't need to be completely removed.
- 7) Support the console, then, remove the last bolt that we had left on the top of the console above the computer board and the console can then be removed.
- 8) Reverse steps to reinstall the console being careful to replace wires, cables and harnesses back the way they were. Install tie wraps as they were.

REMOVE AND REPLACE COMPUTER BOARD

Tools required: ¼” and 3/8” nut driver.

- 1) Open the outside door to the vending machine.
- 2) Open the console door by depressing white latch / release button on the right side of the console adjacent to the bill acceptor.
- 3) Remove the black weatherproof cover from the computer boards.
- 4) Note the harness positions and wiring connections on both boards, marking them if necessary to eliminate reassembly confusion.
- 5) Note the 2 large brown connectors on the left side of the intermediate board and the large white connector on the bottom of the intermediate board. Carefully unplug all three of them, prying, gently, with a small screwdriver.
- 6) Loosen the two ¼” head retaining screws that hold the intermediate board bracket onto the console. Remove the intermediate board with its bracket, leaving the remainder of the wiring attached. Tape the board to the side of the machine and out of your way.
- 7) Unplug the small two-pin connector with the twisted wire from the top left of the computer (large) board (labeled “door”). Remove the white 6-pin connector from the right side of the computer board (labeled “MDB”).
- 8) Using a *BIC* pen with the ink cartridge removed, remove the computer board from the white mounting standoffs. Do not remove the harnesses from the board yet.
- 9) Install the new board onto the standoffs, positioning it the same way as the old board.
- 10) Remove the harnesses from the original board, one at a time, and install them on the new board being careful to install them in the correct positions. The blue connectors for the keypads are identical. Be careful to position them properly, being extra careful to center them on the plugs. They can very easily be installed off by one pin. Each of the blue plugs has a smooth side, while the other side has a series of small contact windows. The side with the windows always faces the board.
- 11) The board has 1 jumper position on it, located 3 ¼ inches from the bottom and 3 inches from the left side (See Figure 1). If your vendor is using M-K Motors (see Figure 1-A), the jumper should be placed over the 2 lower pins. If the vendor is using IG Motors (see Figure 1-B), the jumper should be placed over the two top pins.
- 12) Reinstall the intermediate board reconnecting the two brown connectors on the left side of the intermediate board and the one large white connector on the bottom right of the intermediate board.
- 13) Reseat all of the connectors and verify all connections.
- 14) Before reinstalling the board cover it is necessary to do a RAM clear. Turn all 6 dip switches to the ON position (to the left). The dipswitch block is red in color and is located at the top center of the computer board. Turn on the power to the computer board. The prompt will tell you to press any key. After pressing any key the display will show the board processor checking the RAM, then the Real

Time Clock. At this point it is necessary to power the machine down, reset the dip switches to their original position, and replace the black weather proof cover over the boards, being careful not to pinch any of the wiring. Note: The #2 dipswitch (counting from the bottom of the block) is to enable a two-character selection number and is typically ON (to the left) on all machines.

Figure 1 – Computer Board

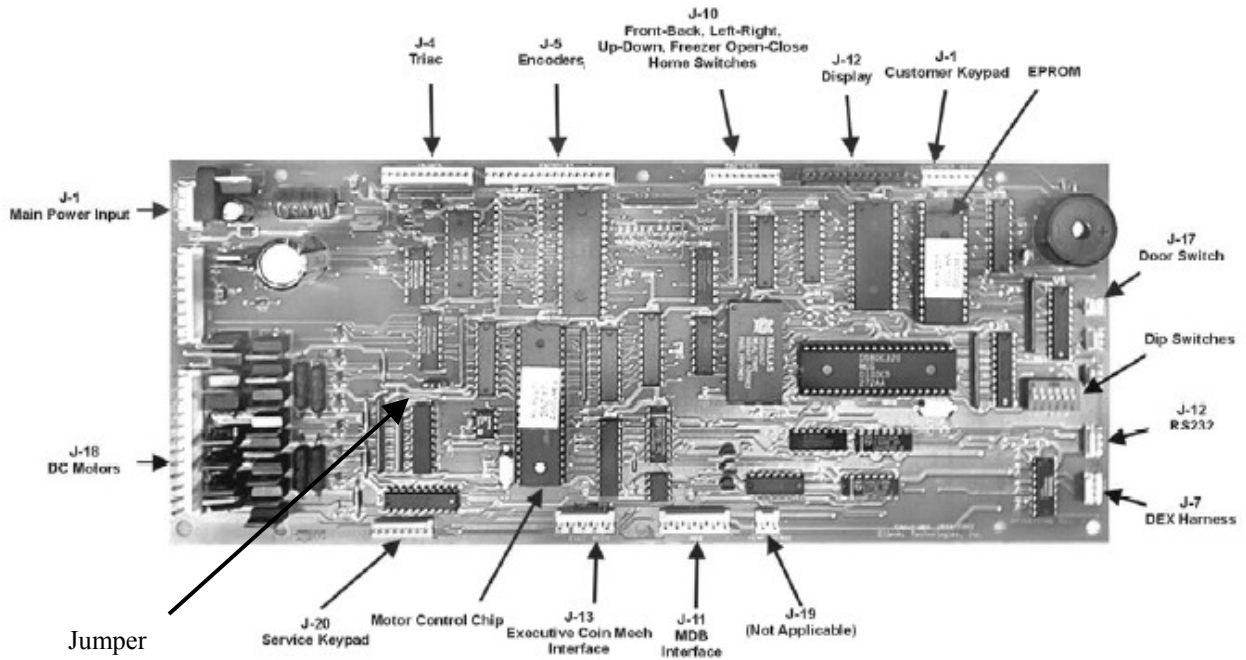
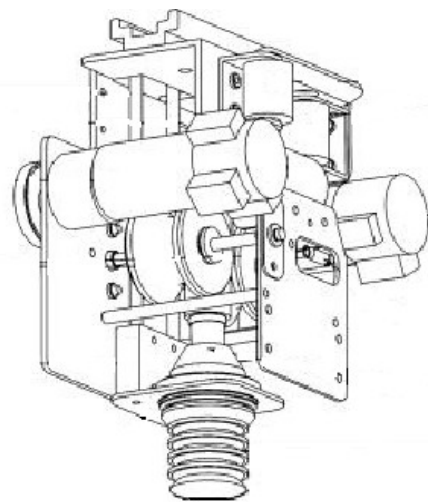
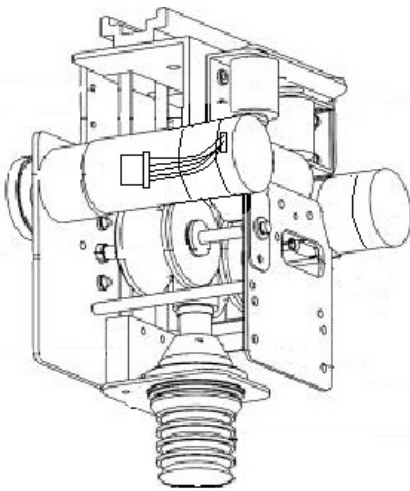

Figure 1-A – Robot w/ IG Motors

Figure 1-B – Robot w/ MK Motors



F820 Front /Back Motor R&R

Tools required: 7/16" wrench, 7/64" Allen wrench, 3/16" nut driver (MK) phillips screwdriver (IG), wire cutters.

Removal – (see fig 2)

- 1) Move robot towards the front and center of the machine. The front / back motor is the second one from the front of the robot, just behind the up / down motor.
- 2) Remove three 1/4" screws from left side of front robot cover. If applicable, remove one 1/4" screw from the right side.
- 3) Remove two 1/4" screws from the metal access plate on the left side of robot to access the motor.
- 4) Cut tie wrap holding ribbon cable to motor, and disconnect the ribbon cable.
- 5) Remove the white gear by unscrewing the 7/64" allen screw holding it to the shaft. If the gear doesn't easily come off after removing the screw, gently pry it.
- 6) Remove the three 3/16"(phillips) screws holding the motor in place.

Reinstallation

- 1) Put new motor in place and line up all three screw holes.
- 2) Install the three 3/16"(phillips) screws, but don't tighten them yet.
- 3) Place the white gear on the motor shaft.
- 4) Slide the motor up until the gears are tight and then back off 1/2 mm. Tighten the one 3/16" screw that is accessible with the white gear on. Ideal gear mesh will allow a piece of paper to pass through the gears, wrinkling it, but not ripping or puncturing it. Manually move the robot front to back the full length of the track to ensure there is no binding or skipping of the new mesh adjustment.
- 5) Remove the white gear and tighten the remaining two 3/16" screws.
- 6) Place the white gear on the motor shaft and secure it with the 7/64" allen screw.
- 7) Plug in the ribbon cable and tie wrap it to the motor.
- 8) Reinstall both robot covers.

Figure 2 – IG Motor (MK mounts the same)

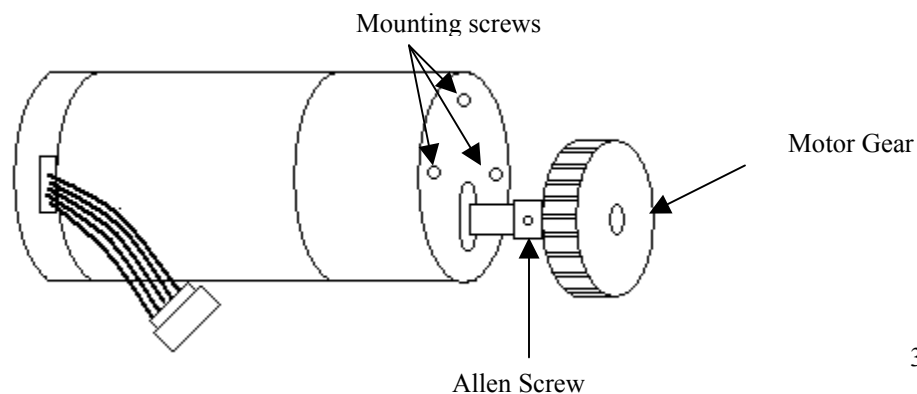

F820 Left / Right Motor R&R

Tools required: 7/16" wrench, 7/64" Allen wrench, 3/16" nut driver, wire cutters, black marker.

Removal - (see fig 2)

- 1) Turn power off.
- 2) Locate and mark the bottom of the left/right motor bracket to assist in realigning the bracket upon installation.
- 3) Remove two 7/16" bolts from adjustment bracket holding Left / Right Motor.
- 4) Cut tie wrap holding ribbon cable to motor, and disconnect the ribbon cable.
- 5) Remove the white gear by unscrewing the 7/64" Allen screw holding it to the shaft. If the gear doesn't easily come off after removing the screw, gently pry it.
- 6) Remove the three 3/16" screws holding the motor in place. *(Note the position of the motor in relation to the mounting bracket)*

Reinstallation

- 1) Put new motor in place and line up all three screw holes.
- 2) Install the three 3/16" screws, and tighten them.
- 3) Place the white gear on the motor shaft and secure it with the 7/64" Allen screw.
- 4) Plug in the ribbon cable.
- 5) Mount the motor/ bracket assembly using the two 7/16" bolts. Don't tighten them yet.
- 6) Slide the assembly up so that the gear mesh is tight, then back off 1mm and tighten the 7/16" bolts. (Ideal gear mesh will allow a piece of paper to pass through the gears, wrinkling it, but not ripping or puncturing it.) Manually move the robot front to back the full length of the track to ensure there is no binding or skipping of the new mesh adjustment.
- 7) Tie wrap the ribbon cable to the motor.

F820 Up/Down Motor R&R

Tools Required: 1/4" and 3/16" nut drivers, Small Phillips screw driver, 7/64" Allen wrench

Removal – (see fig 2)

- 1) Move robot all the way to the front and center of the machine. The up / down motor is located in the front of the robot.
- 2) Remove three 1/4" screws from left side of front robot cover. If applicable, remove one 1/4" screw from the right side.
- 3) Cut tie wrap holding ribbon cable to motor, and disconnect the ribbon cable.
- 4) Remove the white gear by unscrewing the 7/64" allen screw holding it to the shaft. If the gear doesn't easily come off after removing the screw, gently pry it.
- 5) Remove the three 3/16" screws holding the motor in place

Reinstallation

- 1) Put new motor in place and line up all three screw holes.
- 2) Install the three 3/16" screws, and tighten them.
- 3) Place the white gear on the motor shaft and secure it with the 7/64" allen screw. (There is no adjustment for this motor.)
- 4) Plug in the ribbon cable and tie wrap it to the motor.
- 5) Reinstall motor cover.

Removal and Installation of Freezer Motor (F820)

Removal - (see fig 2)

- 1) Located on the left side of the freezer is the "freezer door lift assembly". This is the part that opens and closes the freezer lid. Mark the alignment of the bracket that holds the assembly to the wall for easier reinstallation. Open the freezer lid for easier access to the bolts. Support the assembly and remove the two 3/8" bolts from freezer door lift assembly. Close the freezer lid.
- 2) Lift out the assembly while being careful not to break any of the wires or the ribbon cable. Place the assembly on top of the freezer.
- 3) Disconnect the ribbon cable from the motor and cut the tie wrap.
- 4) Remove the 7/64" allen screw from the white gear and remove the gear.
- 5) Remove the three 3/16" screws holding the motor to the assembly.

Installation

- 1) Connect the ribbon cable to the new motor.
- 2) Mount the new motor using the three 3/16" bolts screws. *Do not tighten them yet.*
- 3) With the toothed arm in place, put the white gear on the motor shaft. *Don't use the allen screw yet.*
- 4) Slide the motor/gear into the rack so that the gear mesh is tight, then back off 1mm and tighten the 3/16" bolt that is accessible, remove the gear and tighten the remaining two bolts. (Ideal gear mesh will allow a piece of paper to pass through the gears, wrinkling it, but not ripping or puncturing it.) Reattach the gear. Manually move the assembly up and down the full length of the track to ensure there is no binding or skipping of the new mesh adjustment.
- 5) Remove the gear and tighten the remaining two screws on the motor.
- 6) Reinstall the gear on its shaft and secure it with the 7/64" allen key.
- 7) Move the arm up and down to ensure it is working smoothly, and reinstall the tie wrap.
- 8) Reinstall the whole assembly using the two 3/8" bolts.
- 9) Adjust the assembly with the two bolts loose so that it is straight vertically and centered horizontally.
- 10) Looking down from the freezer make sure the freezer lid's pin is centered in the lift arm's claw. If the assembly is aligned properly the freezer lid will not hit the back wall of the cabinet.

- 11) Tighten the bolts and test to see if it is working properly by using the “load” and “close” buttons on the service keypad. The lid should open and then close completely.

F820 Picker Head R&R

- 1) Turn Power OFF.
- 2) Pull picker head down.
- 3) Cut tie wrap that holds it to vacuum hose.
- 4) Slide hose up and cut tie wrap holding the wires to the picker head.
- 5) Unplug the wire connector from the picker head. (*Secure the wires so that they don't slip into the hose where they can't be reached.*)
- 6) Plug the connector into the new picker head.
- 7) Tie wrap the wires to the picker head as they were before.
- 8) Slide hose down into place and tie wrap the hose to the new picker head.
- 9) Turn power on.

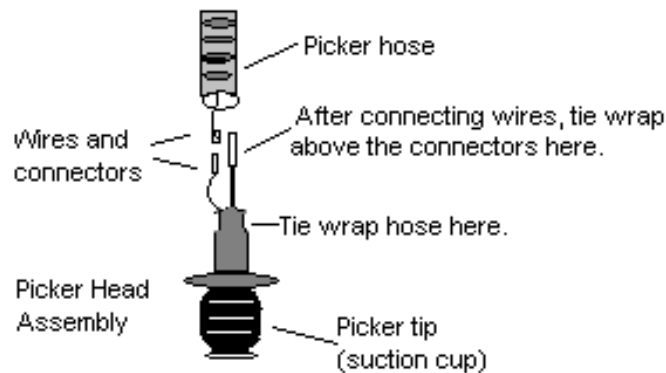

F820 Health Sensor Replacement

Tools required: ¼” nut driver, wire cutting pliers, crimper, electrical tape

- 1) Turn main power off. Turn off the switch that is farthest to the right on the power box, located below the freezer.
- 2) Disconnect 2-pin molex connector that leads to health sensor. The connector is on the right side of the machine behind the console, and is about halfway up behind the coin mech.

- 3) Remove the bins from the freezer for access to the health sensor. It is located directly below the temperature sensor on the side of the "step" inside the freezer. ([Fig. 3](#))
- 4) Remove two ¼ inch screws from health sensor.
- 5) Pull the health sensor so that you have about 4-6 inches of slack. Cut the wires as close as possible to the health sensor.
- 6) Strip the covering off about 1 inch of the slack wire. Twist together and tape the end of the new health sensor's wires to the end of the slack and have someone feed the wires through the hole as you carefully pull the other end through. This will route the new wires to where the old wires were.
- 7) Once the wire is fed under the freezer and to the front of the machine, remove the tape and discard the old wire.
- 8) Crimp the end of the new health sensor's wires to the two pins provided in the health sensor kit.
- 9) Insert the pins into the new molex connector until they click into place.
- 10) Plug in to the matching connector located on the right side of the machine behind the console, and about halfway up behind the coin mech., secure the wires.
- 11) Install the new health sensor in place using the two¼ inch screws provided.

Figure 3

View looking into freezer

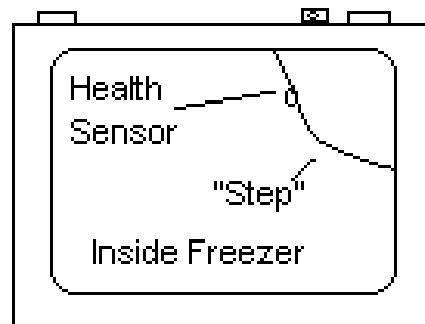

Front

REMOVE AND REPLACE THE FRONT LEXAN BUBBLE

Tools required: ¼” nut driver, 11/32” magnetic long reach nut driver, box cutter knife

- 1) Remove the *Display Card Holder* through the access slot on the back of the *Door Assy*.
- 2) Remove the (3) three *Card Holder Spring Clips* (part # 488 00201) by loosening the ¼” headed screws and sliding them off.
- 3) Remove the *Customer Bin Assy* (part # 493 30270) from the back of the vending machine door by removing the (17) seventeen retaining screws using a ¼” nut driver.
- 4) Remove the (8) eight retaining nuts from the *Customer Bin Bezel Welded Assy* (part # 493 30350) by using an 11/32” magnetic long reach nut driver. These nuts can be accessed through ½” diameter clearance holes around the inside opening of the *Bezel*. The *Customer Bin Bezel Welded Assy* can then be removed from the front of the machine by gently pulling it.
- 5) Remove the *Top Bubble Support Welded Assy* (493 30356) for the *Front Door Bubble Panel* by removing the seven retaining screws from the top, rear of the door using a ¼” nut driver.
- 6) Run a box cutter along the seam between the *Top Bubble Support Welded Assy* and the door top to break the silicon seal.
- 7) Lift the *Front Door Bubble Panel* up by grabbing the delivery door opening and pull up and out.
- 8) Before reinstalling the new *Front Door Bubble Panel*, remove the protective film from both sides of the *Bubble Panel*. Take special care with the new panel so that it does not get scratched or damaged.
- 9) Reinstall the new *Front Door Bubble Panel* by inserting one edge into a side *Front Bubble Support* (part # 493 34702), then, bowing the bubble and slipping it into the *Front Bubble Support* on the other side. Once the *Front Door Bubble Panel* is seated into the side supports, slide it down and into the *Bottom Bubble Support Welded Panel* (part # 493 30347).
- 10) Reinstall the *Top Bubble Support Welded Assy*, threading and tightening the (7) seven screws. You may have to push out on the *Front Door Bubble Panel* from the inside through the display card holder slot to properly align it.
- 11) Seal the seam between the *Top Bubble Support Welded Assy* and the *Door Weld Assy* using a black silicon sealer or the equivalent.
- 12) Reinstall the *Customer Bin Bezel Welded Assy* using the original (8) eight 11/32” nuts.
- 13) Reinstall the *Customer Bin Assy* using the original (17) seventeen ¼” headed screws.
- 14) Reinstall the 3 card holder spring clips.
- 15) Reinstall the display card holder.